

TB2150



OPERATING PERFORMANCE

Operating Weight	15,095 kg
Bucket Capacity (Heaped)	0.45 m ³
Slew Speed	10.8 min ⁻¹
Travel Speed	
1st	3.1 km/h
2nd	5.5 km/h
Gradeability	35°
Ground Pressure	47.1 kPa
Maximum Bucket Breakout Force	96.3 kN
Maximum Arm Digging Force (2,320 mm Arm)	59.8 kN
Maximum Arm Digging Force (2,570 mm Arm)	55.8 kN
Traction Force	145 kN
Boom Swing Angle (Left/Right)	77°/ 53°

ENGINE

Model	DEUTZ TCD3.6L4
Rated Output (ISO 14396)	85 kW/2000 min ⁻¹
Maximum Torque	460 Nm/1600 min ⁻¹
Displacement	3,621 ml
Alternator	28 V-2.24 kW
Battery (IEC 60095-1)	12 V - 90Ah x 2

FLUID CAPACITIES

Engine Lubrication	10 L
Cooling System	27 L
Fuel Tank Capacity	278 L
Hydraulic Reservoir Capacity	107 L
Hydraulic System Capacity	234 L
DEF Tank Capacity	20 L

SAFETY and HEALTH

Vibration Levels	
Hand / Arm	≤ 2.5 m/s ²
Body	≤ 0.5 m/s ²
Noise Level	
Sound Power Level	LWA 98 dB

HYDRAULIC SYSTEM

P1, P2	Variable Displacement Pump
Flow Rate	112 L/min
Relief Pressure	34.3 MPa
P3	Gear Pump
Flow Rate	20 L/min
Relief Pressure	3.9 MPa
P4	Gear Pump
Flow Rate	54.8 L/min
Relief Pressure	23.6 MPa
Service Port 1	
Flow Rate	112 L/min
Flow Rate - High Flow	224 L/min
Hydraulic Pressure	24.5 MPa
Service Port 2	
Flow Rate	54.8 L/min
Hydraulic Pressure	23.6 MPa
Service Port 3	
Hydraulic Pressure	21.0 MPa
Service Port 4	
Flow Rate	54.8 L/min
Hydraulic Pressure	23.6 MPa

Operating Weight: 15,095 kg

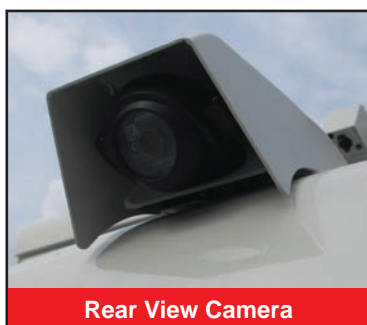

Rear View Camera



Multi-Function Switch Bank



Hydraulic Fan Drive for Radiator



Optional Dozer Blade with Float

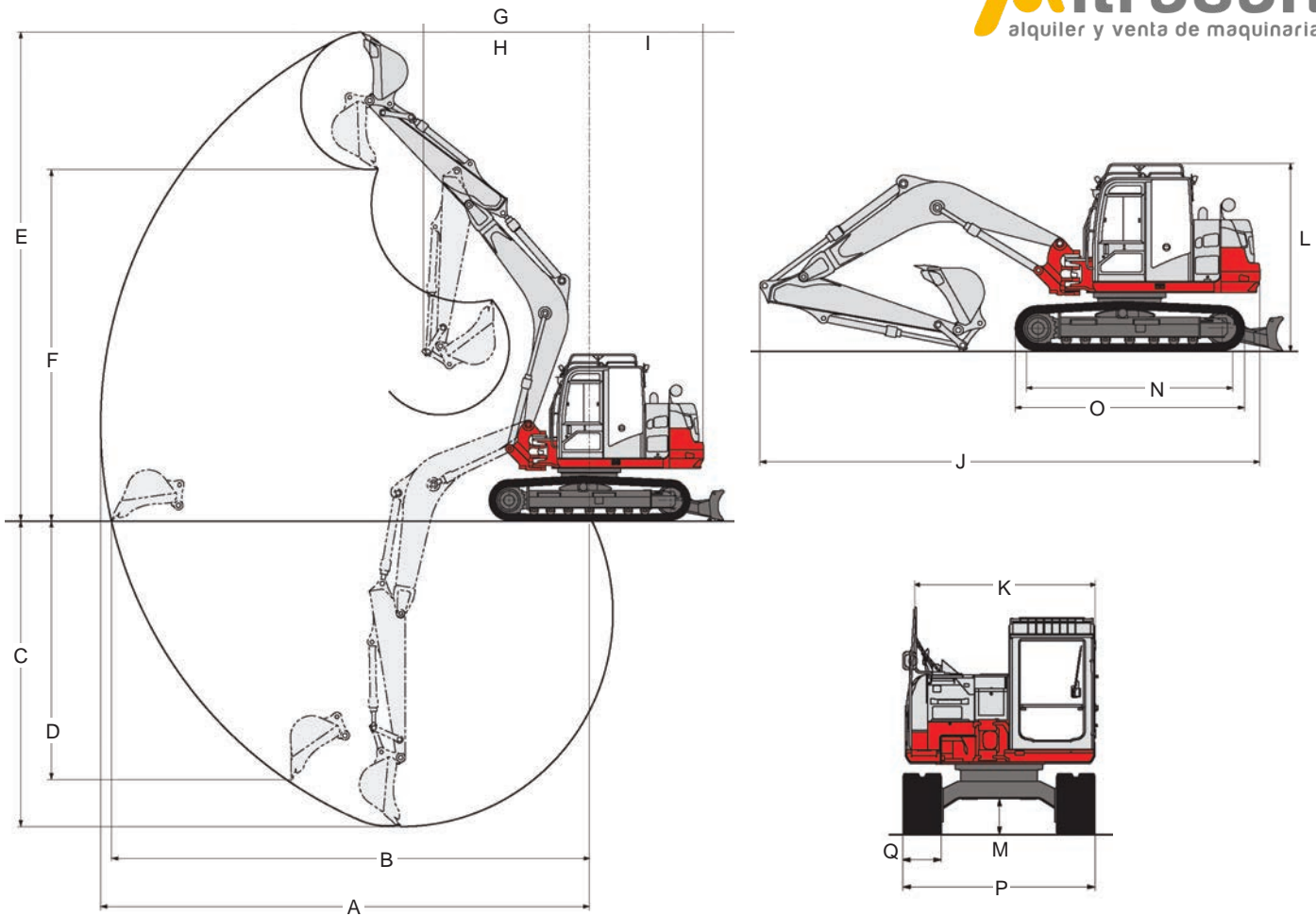

MACHINE DIMENSIONS	2,320 mm ARM	2,570 mm ARM
A Maximum Reach	8,520 mm	8,760 mm
B Maximum Reach at Ground Level	8,320 mm	8,565 mm
C Maximum Digging Depth	5,195 mm	5,445 mm
D Maximum Vertical Digging Depth	4,365 mm	4,605 mm
E Maximum Height of Cutting Edge	8,520 mm	8,700 mm
F Maximum Dumping Height	6,070 mm	6,250 mm
G Front Swing Radius	2,965 mm	3,015 mm
H Front Swing Radius with Boom Offset	2,360 mm	2,405 mm
I Slew Radius		2,000 mm
I' Slew Radius with Extra Weight		2,050 mm
J Overall Length	7,770 mm	7,805 mm
J' Overall Length with Extra Weight	7,820 mm	7,855 mm
K Upper Structure Overall Width		2,500 mm
L Overall Height		2,960 mm
M Ground Clearance		475 mm
N Crawler Base		2,895 mm
O Crawler Overall Length		3,615 mm
P Crawler Overall Width		2,490 mm
Q Crawler Shoe Width		500 mm