

ESPECIFICACIONES A30E

Pos.	Sistema métrico (mm)		Sistema británico (Feet)	
	A25E	A30E	A25E	A30E
A	10 220	10 297	33'6"	33'9"
A ₁	4 954	4 954	16'3"	16'3"
A ₂	5 764	6 002	18'11"	19'8"
B	5 152	5 339	16'11"	17'6"
C	3 428	3 428	11'3"	11'3"
C ₁	3 318	3 318	10'11"	10'11"
C ₂	1 768	1 768	5'10"	5'10"
C ₃	3 760	3 834	12'4"	12'7"
D	2 764	2 764	9'1"	9'1"
E	1 210	1 210	4'0"	4'0"
F	4 175	4 175	13'8"	13'8"
G	1 670	1 670	5'6"	5'6"
H	1 610	1 688	5'3"	5'6"
I	608	608	2'0"	2'0"
J	2 778	2 856	9'1"	9'4"
K	2 102	2 181	6'11"	7'2"
L	677	686	2'3"	2'3"
M	6 559	6 592	21'6"	21'8"
N	8 105	8 105	26'7"	26'7"
N ₁	4 079	4 037	13'5"	13'3"
O	2 700	2 900	8'10"	9'6"
P	2 490	2 706	8'2"	8'11"
R	512	513	1'8"	1'8"
R ₁	634	635	2'1"	2'1"
U	3 257	3 310	10'8"	10'10"
V	2 258	2 216	7'5"	7'3"
V*	-----	2 258	-----	7'5"
W	2 859	2 941	9'5"	9'8"
W*	-----	2 859	-----	9'5"
X	456	456	1'6"	1'6"
X ₁	581	582	1'11"	1'11"
X ₂	659	659	2'2"	2'2"
Y	2 258	2 216	7'5"	7'3"
Y*	-----	2 258	-----	7'5"
Z	2 859	2 941	9'5"	9'8"
Z*	-----	2 859	-----	9'5"
a ₁	23.5°	23.5°	23.5°	23.5°
a ₂	74°	70°	74°	70°
a ₃	45°	45°	45°	45°

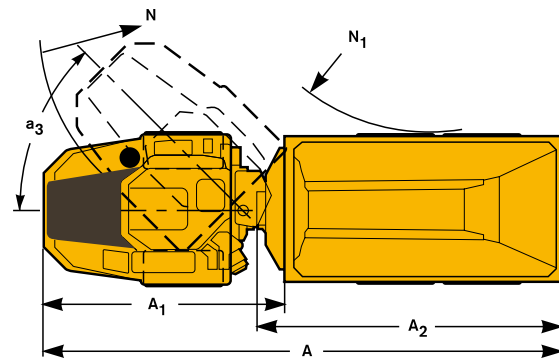
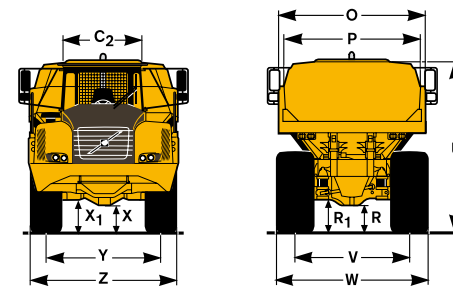
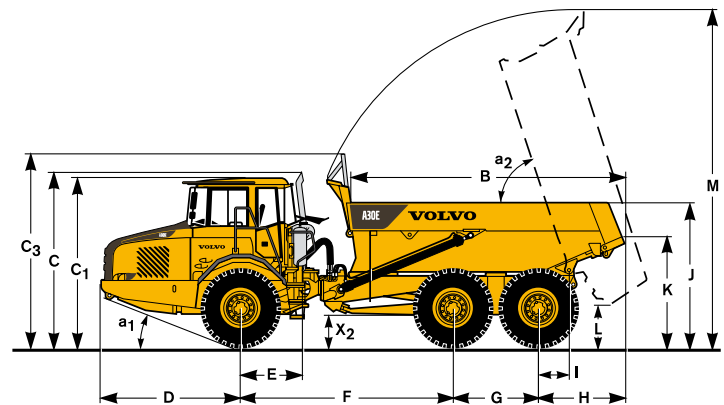

A25E: máquina sin carga con 23,5 R25
 A30E: máquina sin carga con 750/65R25
 *) A30E con neumáticos opcionales 23,5 R25

ESPECIFICACIONES A30E

Capacidad de carga

	A25E		A30E	
Caja estándar				
Capacidad de carga	24 000 kg	26.5 sh tn	28 000 kg	31.0 sh tn
Caja, al ras	11,7 m ³	15,3 yd ³	13,6 m ³	17,8 yd ³
Caja, colmada	15,0 m ³	19,6 yd ³	17,5 m ³	22,9 yd ³
Con compuerta trasera suspendida				
Caja, al ras	12,0 m ³	15,7 yd ³	13,8 m ³	18 yd ³
Caja, colmada	15,3 m ³	20 yd ³	18,0 m ³	23,5 yd ³
Con compuerta trasera en voladizo				
Caja, al ras	12,1 m ³	15,8 yd ³	14,0 m ³	18,3 yd ³
Caja, colmada	15,6 m ³	20,4 yd ³	18,1 m ³	23,7 yd ³
Con compuerta trasera suspendida y en voladizo				
Caja, al ras	12,1 m ³	15,8 yd ³	- m ³	- yd ³
Caja, colmada	15,6 m ³	20,4 yd ³	- m ³	- yd ³

Pesos

	A25E		A30E	
Neumáticos	23.5R25		750/65R25	
Peso en orden de marcha, sin carga				
Delante	12 160 kg	26 808 lb	12 500 kg	27 557 lb
Atrás	9 400 kg	20 723 lb	10 560 kg	23 280 lb
Total	21 560 kg	47 531 lb	23 060 kg	50 838 lb
Carga útil	24 000 kg	52 910 lb	28 000 kg	61 729 lb
Pesos totales				
Delante	14 140 kg	31 173 lb	14 990 kg	33 047 lb
Atrás	31 420 kg	69 269 lb	36 070 kg	79 520 lb
Total	45 560 kg	100 442 lb	51 060 kg	112 568 lb

El peso en orden de marcha incluye todos los líquidos y el conductor.

Peso sobre el suelo

	A25E		A30E			
Neumáticos	23.5R25		750/65R25		23.5R25	
Sin carga						
Delante	123 kPa	17.8 psi	101 kPa	14.6 psi	127 kPa	18.4 psi
Atrás	48 kPa	7.0 psi	43 kPa	6.2 psi	54 kPa	7.8 psi
Con carga						
Delante	144 kPa	20.8 psi	121 kPa	17.5 psi	152 kPa	22.0 psi
Atrás	159 kPa	23.0 psi	146 kPa	21.2 psi	183 kPa	26.5 psi

Velocidad

	A25E		A30E	
Adelante				
1	8 km/h	5.0 mph	8 km/h	5.0 mph
2	12 km/h	7.5 mph	12 km/h	7.5 mph
3	22 km/h	13.6 mph	22 km/h	13.6 mph
4	31 km/h	19.3 mph	31 km/h	19.3 mph
5	40 km/h	24.8 mph	40 km/h	24.8 mph
6	53 km/h	32.9 mph	53 km/h	32.9 mph
Atrás				
1	8 km/h	5.0 mph	8 km/h	5.0 mph
2	13 km/h	8.1 mph	13 km/h	8.1 mph

Capacidades

	A25E		A30E	
Cárter	40 litros	10.6 US gal	40 litros	10.6 US gal
Depósito de combustible	400 litros	106.0 US gal	400 litros	106.0 US gal
Sistema de refrigeración	115 litros	30.4 US gal	115 litros	30.4 US gal
Transmisión, total	41 litros	11.0 US gal	41 litros	11.0 US gal
Caja de reenvío	8,5 litros	2.2 US gal	8,5 litros	2.2 US gal
Ejes, delantero/ trasero	33 litros	8.7 US gal	33 litros	8.7 US gal
Eje delantero del bogie	34 litros	9.0 US gal	34 litros	9.0 US gal
Depósito hidráulico	175 l litros	46.0 US gal	175 litros	46.0 US gal

Material de la caja

Delante	8 mm	0.31"
Lados	12 mm	0.47"
Plataforma	14 mm	0.55"
Rampa	14 mm	0.55"
Límite de elasticidad	1000 N/mm ²	145 000 psi
Resistencia a la tracción	1250 N/mm ²	181 000 psi
Dureza	400 HB	