

MRT 1432 *M Series*



Lift capacity (on stabilisers)3200 kg
at 500 mm from forks heels



Lift height :13.82 m



Tyres
400/70 - 20 14 PR



Forks (mm)
Length1200
Width x thickness125 X 45



Multidisc brakes : hydraulically assisted on front axle
Negative parking brake



Engine PERKINS
Type1004.40 Turbo
Capacity4 cyl. 3990 cm³
Power (ISO/TR 14396)106 HP/78.5 kw
at 2300 rpm
Water cooling
Direct injection



Transmissionhydrostatic
With automatic power regulation (hydraulic variable
displacement pump and motor)
Reversing shiftelectromagnetic
2 speed forward and reverse
Travel speed25 km/h



Rear axle
Automatic rear axle locking system
over 15 ° rotation



4 stabilisers
simultaneous or individually controlled



Rotation through 400°
Turret mounted on a double slew ring



Hydraulics
2 pumps gear type270 bars/115 l/mn



Control : 2 electro proportional control joysticks for all
hydraulic movements



Capacities
Cooling system15 l.
Engine oil8,1 l.
Hydraulic oil140 l.
Fuel tank130 l.



Weight unladen (with forks)12450 kg
Overall width2.39 m
Overall height2.97 m
Overall length5.35 m
Ground clearance0.34 m
Drawbar pull9900 daN



Standard load moment indicator
(mobile crane standards)

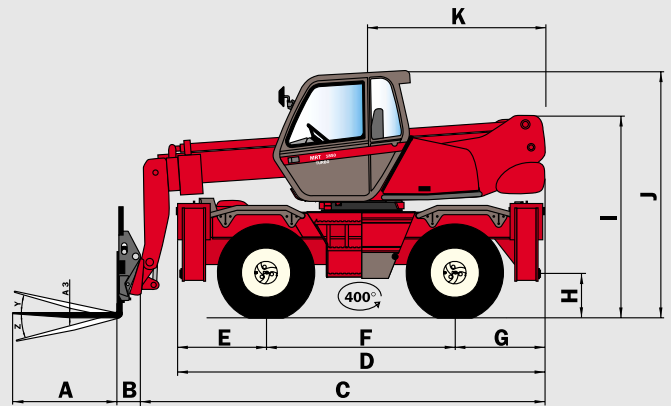

A	1200
A1	125
A2	1320
A3	45
B	290
C	5060
D	4350
E	1015
F	2320
G	1015
H	340
I	2365
J	2970
K	2040
L	1930
M	2390
N	3400
O	3800
P	160
Q	3900
R	3410
S	4000
V	950
Y	12°
Z	105°

mm

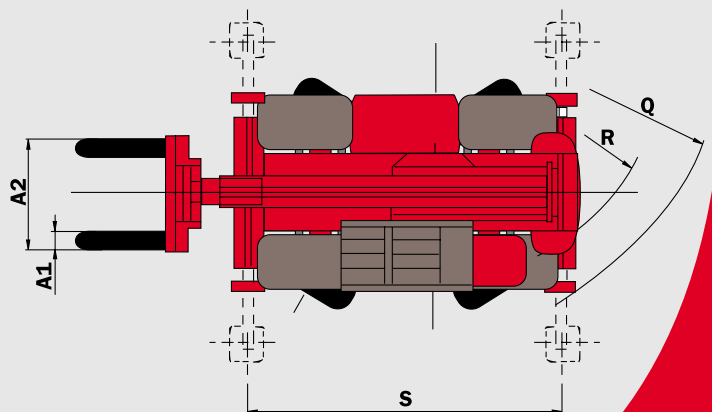
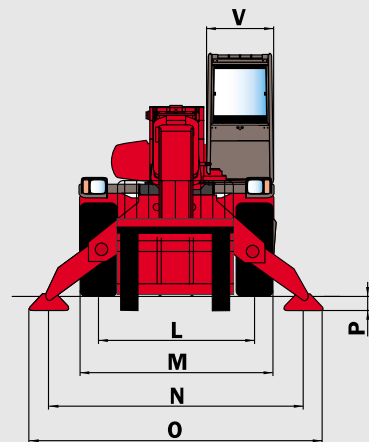

ROTATION ON STABILISERS WITH FORKS

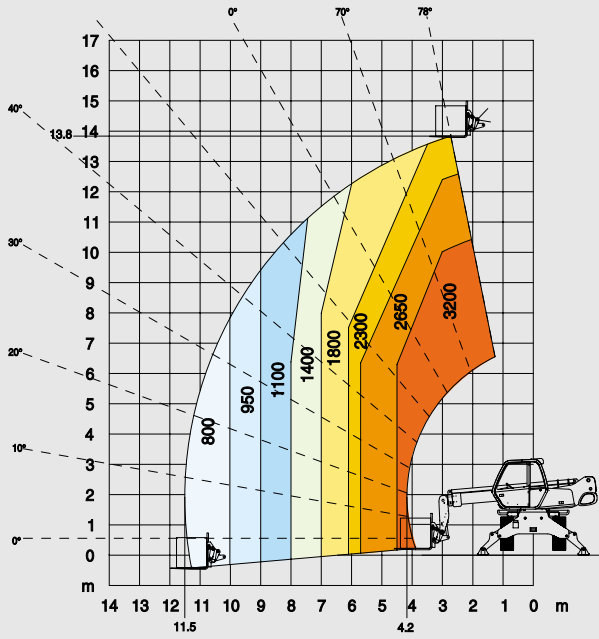

FRONTAL POSITION ON WHEELS WITH FORKS

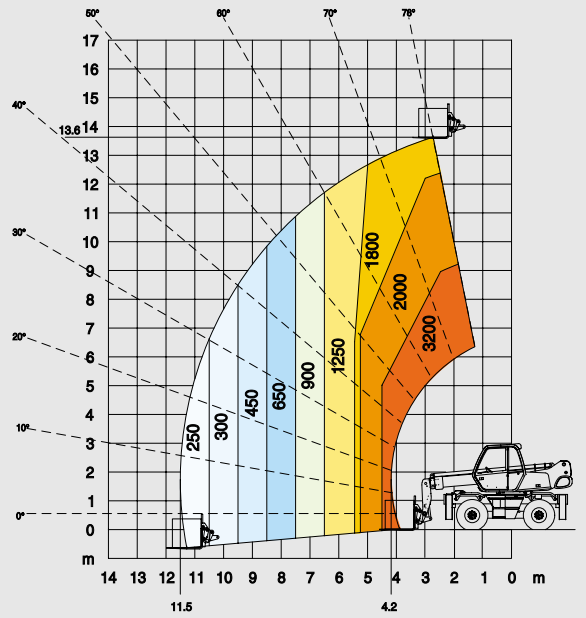

ROTATION ON WHEELS WITH FORKS

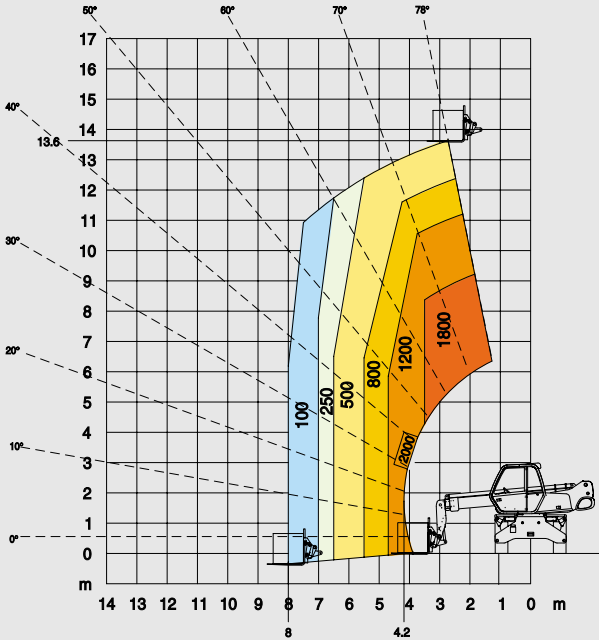

ROTATION ON STABILISERS WITH 3T WINCH

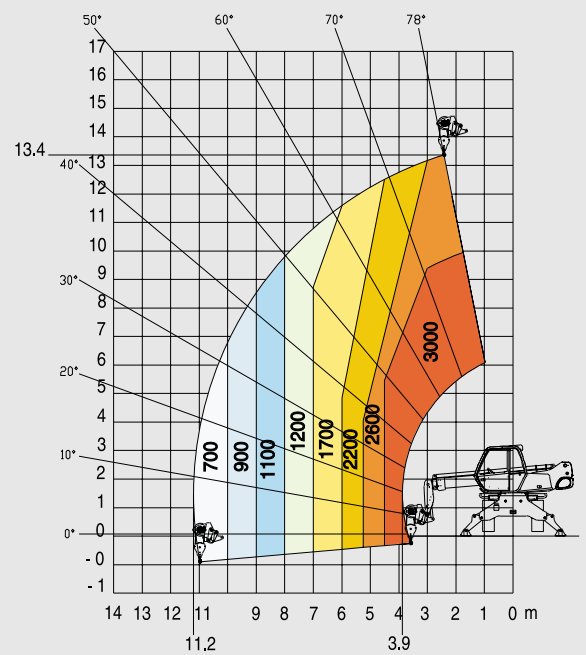

ROTATION ON STABILISERS WITH JIB P 600

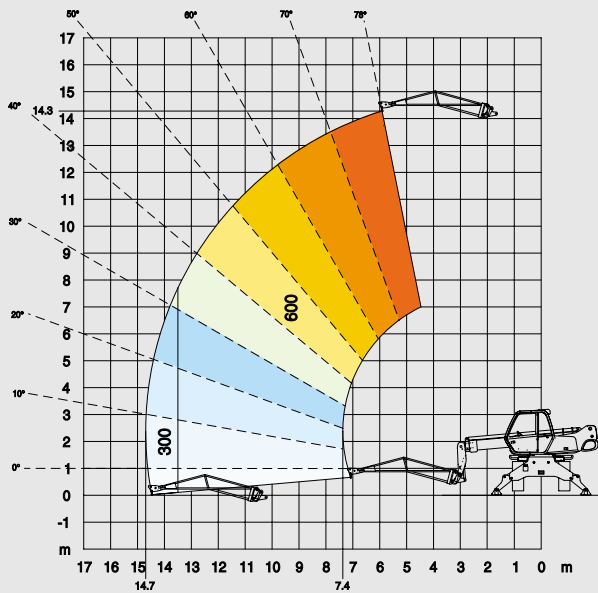

ROTATION ON STABILISERS WITH JIB P 1500

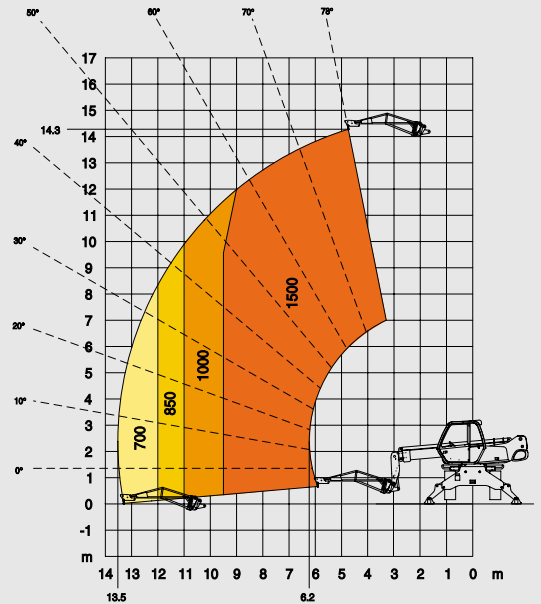

**ROTATION ON STABILISERS
WITH EXTENSIBLE PLATFORM 2,25/4 m**

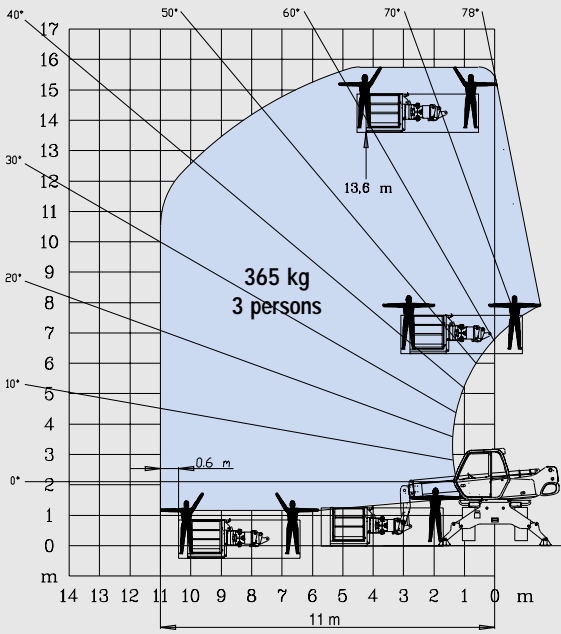

**ROTATION ON STABILISERS
WITH 1000 KG PLATFORM 2,25/4 m**

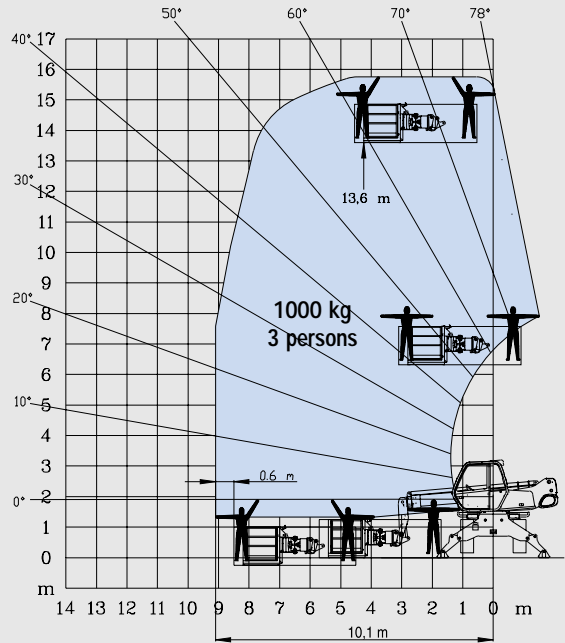

**ROTATION ON STABILISERS
WITH 3 D SYSTEM IN POSITIVE POSITION**

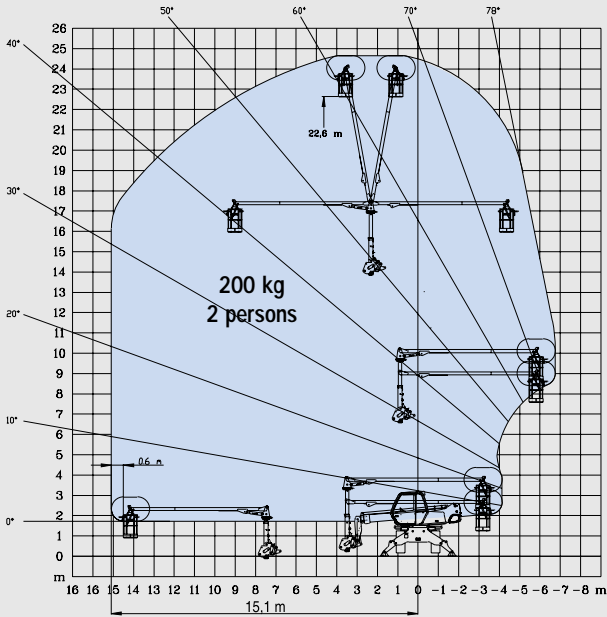

**ROTATION ON STABILISERS
WITH 3 D SYSTEM IN NEGATIVE POSITION**

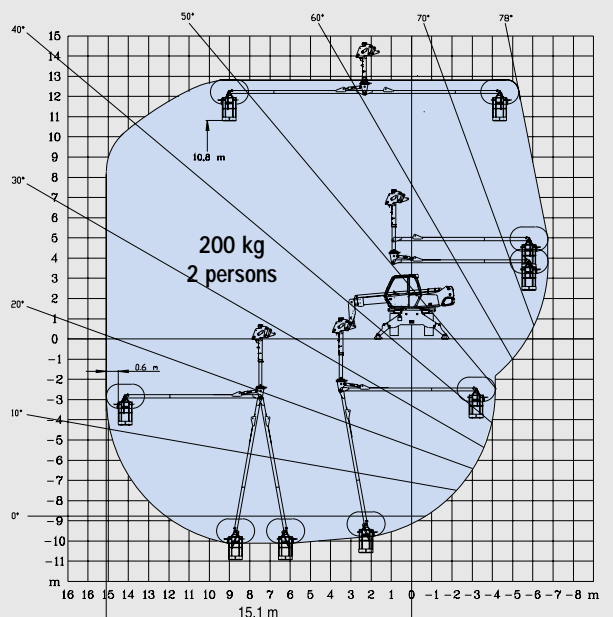

**ROTATION ON STABILISERS
WITH AERIAL JIB PLATFORM**

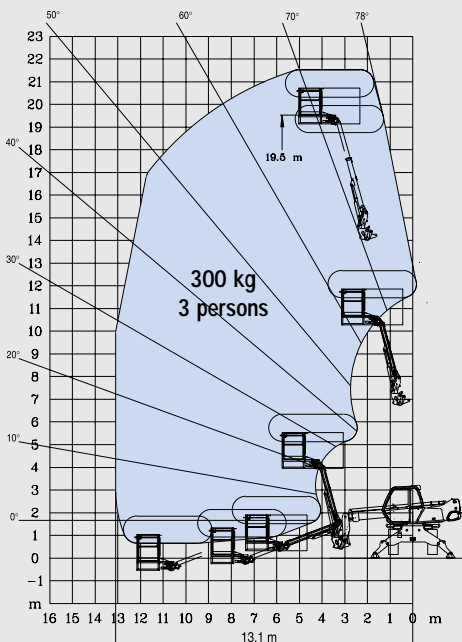

**Equipment customised
on order**

