

VMT380 AND VMT430 TANDEM ESPECIFICACIONES

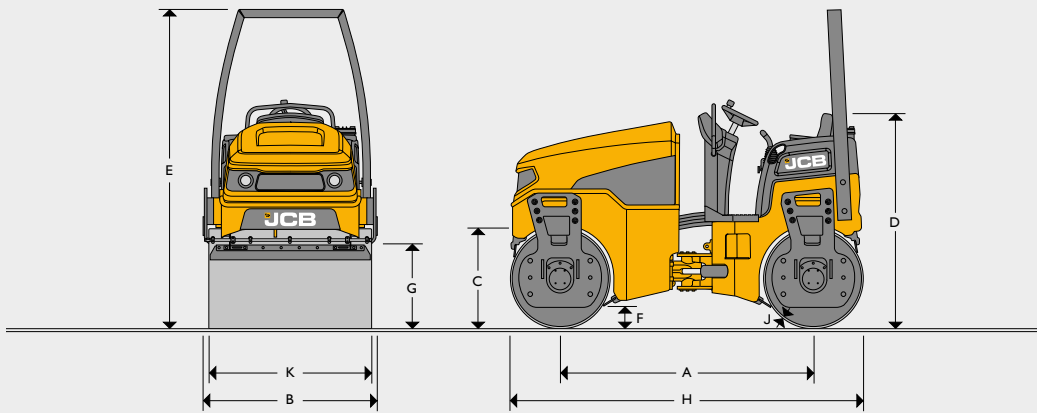

STATIC DIMENSIONS



Dimensions in millimetres		VMT380-130	VMT380-140	VMT430-130	VMT430-140
A	Wheelbase	2020	2020	2020	2020
B	Overall width	1390	1490	1390	1490
C	Drum diameter	800	800	800	800
D	Height to top of seat	1720	1720	1720	1720
E	Height to top of ROPS	2550	2550	2550	2550
F	Ground clearance	300	300	300	300
G	Curb clearance	680	680	680	680
H	Total travel length	2820	2820	2820	2820
J	Drum thickness	17	17	17	17
K	Drum width	1300	1400	1300	1400

OPERATION DATA

		VMT380-130	VMT380-140	VMT430-130	VMT430-140
Operating weight (CECE)	kg	3750	3850	4200	4300
Maximum operating weight*	kg	4100	4200	4550	4650
Operating linear load	kg/cm	14.4	13.8	16.2	15.4
Exciter frequency	Hz	50 / 59 / 66	50 / 59 / 66	50 / 59 / 66	50 / 59 / 66
Nominal amplitude	mm	0.44	0.44	0.44	0.44
Centrifugal force (each drum)	kN	59	63	59	63
Working speed range	km/h	0 - 9	0 - 9	0 - 9	0 - 9
Drum offset right	mm	80	80	80	80
Steering lock angle	°	± 36	± 36	± 36	± 36
Oscillation angle	°	± 13	± 13	± 13	± 13
Inner turning radius	mm	2490	2440	2490	2440
Max. gradeability without vibration (dependant on site conditions)	° (%)	22.8 (42)	22.8 (42)	22.8 (42)	22.8 (42)

ENGINE

Make	Kohler		
Model	KDW 2204 (TIER4i)		
Type	4 -Stroke Diesel, liquid cooled		
Piston displacement	cm ³	2199	
Performance	kW (hp)	33.6 (45.7)	
Operating speed	min-1 (rpm)	2700	
Starting device	Electric motor		
Air cleaner	Dry cartridge plus safety cartridge		
Fuel filter	Cartridge		

PROPULSION

Hydrostatic with variable displacement pump and fixed displacement motors with direct drive to both drums = double drum drive.

EXCITER DRIVE

Electrically controlled hydrostatic direct drive on both drums for double vibration or single vibration front or rear.

EXCITER

Single-piece circular exciter shaft with one amplitude and three frequencies.

STEERING SYSTEM

Servo assisted, maintenance free articulation with oscillation facility.

SERVICE CAPACITIES

Fuel	litres	100
Sprinkler water	litres	210

BRAKING SYSTEM

Service brake	Hydrostatic drive	
Parking brake	SAHR	

ELECTRICAL SYSTEM

Working lights, backup alarm, safety switch in operators seat.		
Voltage	V	12
Battery capacity	Ah	74
Alternator	A	80